



PRECISION CUTTING TOOLS, INC.

ENDMILLS

HIGH-PERFORMANCE ROUGHER



POWDER METAL PM30

4, 5, 6 & 8 Flute
Coarse Pitch Roughing Endmills

The Powder Metal Coarse Pitch Endmill is engineered for roughing Titanium and Stainless Steels. Its coarse teeth and center-cutting design allow for heavy cuts on tough materials. In addition, our Coarse Pitch Endmill also comes with Weldon Flats to help reduce tool slippage during machining.

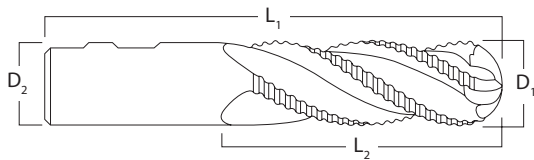

PM30	4, 5, 6, 8 Flutes	30°	Coarse Rougher
-------------	-----------------------------	------------	-------------------

Exxtral Plus[®] Exxtral Plus[®] is ideal for high-performance machining of hard materials.

Benefits:

- Increased metal removal rates
- Improved accuracy
- Chatter-free machining
- High speeds & feeds
- Longer Tool Life

Applications:

- Titanium
- Stainless Steels
- ...and their alloys

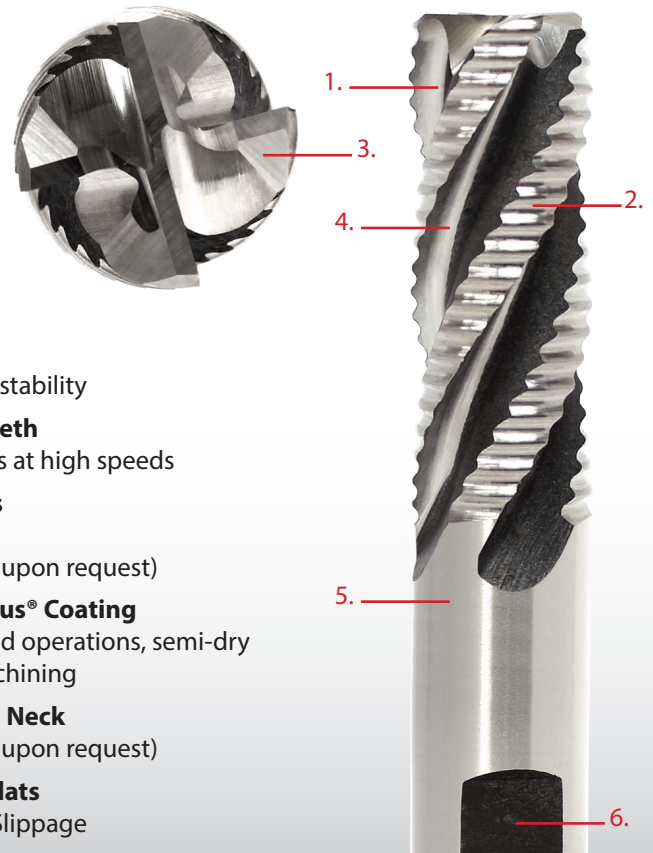

- 30° Helix**
Increased stability
- Coarse Teeth**
Heavy cuts at high speeds
- 4-8 Flutes**
Left-Hand
(Available upon request)
- Exxtral Plus[®] Coating**
High-speed operations, semi-dry or dry machining
- Extended Neck**
(Available upon request)
- Weldon Flats**
Reduced Slippage

Proudly Manufactured in the
United States of America



(562) 921-7898 | sales@pctcutters.com | www.pctcutters.com